

The background of the page is a photograph of industrial machinery, likely a water treatment plant. It features large blue metal frames, stainless steel pipes, and various valves and pumps. In the foreground, there are several large electric motors with blue and orange components. The sky is blue with some light clouds. The overall scene is brightly lit, suggesting an outdoor industrial setting.

# **NOVARIS**

Application Note  
(0015-D67V2)

## **DIVERTERS, SSP AND FILTER PERFORMANCE**

**Novaris Pty Ltd**

72 Browns Road Kingston  
P.O. Box 2010 Kingston  
Tasmania 7050 Australia

+61 3 6229 7233  
sales@novaris.com.au  
[www.novaris.com.au](http://www.novaris.com.au)

# CONTENTS

## 02 - 03

Introduction  
Background to Performance  
Surge Diverters

## 04

Series Surge Protectors

## 05 - 07

Surge Filters  
Advantages of Surge Filters  
Lifespan and Reliability  
Conclusions  
Other Voltage and Protocol Protection

## Introduction

For the protection of power systems, both AC and DC, there are three families of Surge Protection Devices (SPD) that are most commonly used.

These are surge diverters (SD), series surge protectors (SSP) and surge filters (SF).

**Surge Diverters** connect in parallel between power conductors or between power conductors and a neutral or earth with the aim of 'shunting or diverting' the surge energy away to neutral or ground. Generally, SD's are a single port device, they most usually have two connection terminals (more if they are packaged into group modules) and are connected between lines.

**Series Surge Protectors** connect in parallel in a similar way to diverters but have two sets of terminals connected together inside the unit. This allows the wiring to be done with an input side and a equipment or load side so that voltage drop caused by wiring inductance is eliminated.

**Surge Filters** are more complex multistage SPDs that use filtering as well as diverting technology all combined into a single SPD package to provide much improved performance.

SF's are two port devices that are connected in series with the circuits to be protected so that the load or equipment side is separated from the dirty power side by the components contained inside.

The performance of the three types of devices differs greatly and there are some key differences in application. This application note details these differences, showing some test results, with the aim to allow engineers to make an appropriate selection of an SPD to protect their power equipment.

## Background to Performance

When selecting surge protection devices one of the key differentiating factors is their let through voltage. The let through voltage is the voltage that the equipment to be protected is exposed to when the SPD is operated. This can be a transverse or common mode voltage. These let through voltages increase as the surge current increases.

The Australian Standard on Lightning Protection (AS1768) defines a standard combination waveform consisting of a 1.2/50us 6kV voltage peak combined with an 8/20us 3kA current peak. The let through voltage is the residual voltage the load is exposed to (equipment to be protected) downstream of the surge protection device.

To get a better understanding of the let through voltages associated with higher energy surges, 1.2/50us 20kV, 8/20us 10kA (short circuit) surges have been included. These surges are more representative of what equipment will be exposed to in LPZ1/2 and LPZ2/n as defined in AS 1768.

Lower let through voltages provide better protection for more sensitive equipment. Some surge protection manufacturers use lower voltage components to achieve a lower voltage let through at the expense of reliability. Novaris uses 275V and 320V MOVs for their 240V products to provide adequate headroom for tolerable voltage fluctuations. If lower let through voltages are required Novaris can provide a range of surge filters that offer excellent performance without sacrificing reliability.

## Surge Diverters

Surge diverters are connected in parallel. They consist of surge arresting components, usually metal oxide varistors (MOVs) and gas arresters. They work by diverting surge energy to ground.

A typical let-through voltage waveform for a surge diverter is shown in Figure 1 below:

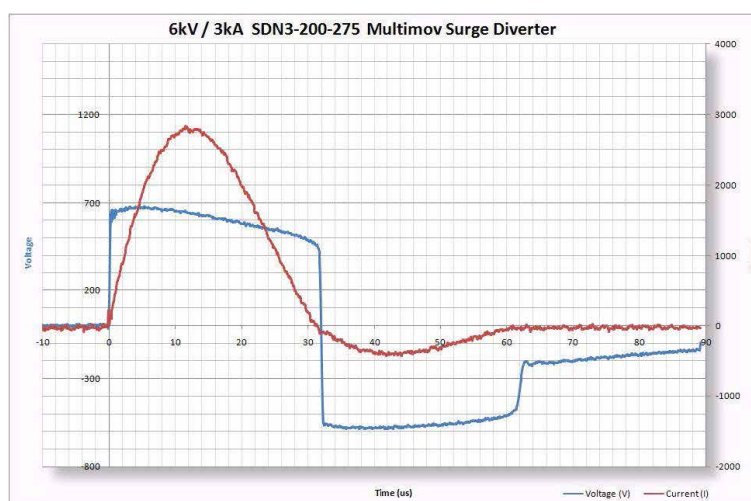
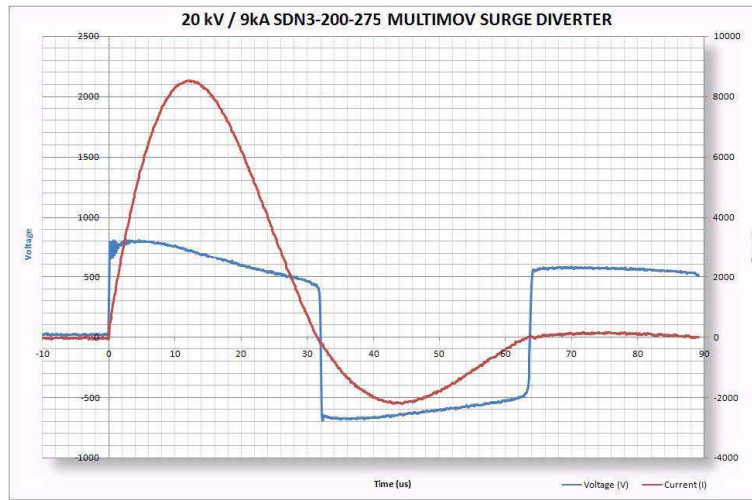

Figure 1. Typical Let-through Voltage of a Surge Diverter (6kV / 3kA)

The let-through voltage shown here is just under 700V. Whilst this is low enough to protect most power equipment, such as transformers, more sensitive electronic equipment, such as switch mode power supplies and electronics with integral power supplies, would still be damaged by a surge of this magnitude. Surge diverters that employ other components such as Silicon Avalanche Diodes (SADs or Transzorbs) can have lower let-through voltages (as low as 600V); however, this is generally at the expense of the reliability and lifetime of the surge diverter.



**Figure 2.** Typical let-through of a surge diverter (20kV / 10kA)

As can be seen in Figure 2, the scaling for let through voltage is not linear based on the current applied. When this more representative 10kA (the peak current is reduced slightly by circuit wiring impedances) surge is applied it can be seen that the let through voltage increases to around 800 volts, this can be high enough to damage most electronic equipment.

Surge diverter performance is affected greatly by the fact that surge currents have to pass through the connecting leads. The inductance of the leads can increase the effective let through voltage to the equipment by a factor of two or three times depending on the installation. This mechanism is important to understand and is explained in detail in the section 'Effect of shunt-connected leads' on page 7.

### Series Surge Protectors

Series Surge Protectors as their name suggests are connected in series between the incoming line side and the equipment load side. Because of this the maximum current draw for the connected equipment must be known and the current rating of the SSP be at least equal to this value.

As there are two separate sets of terminals the voltage drop caused by the surge current flowing on the line side is not added to the equipment side like a diverter, the voltage presented to the equipment is exactly what it produced at the equipment side terminals of the SSP.

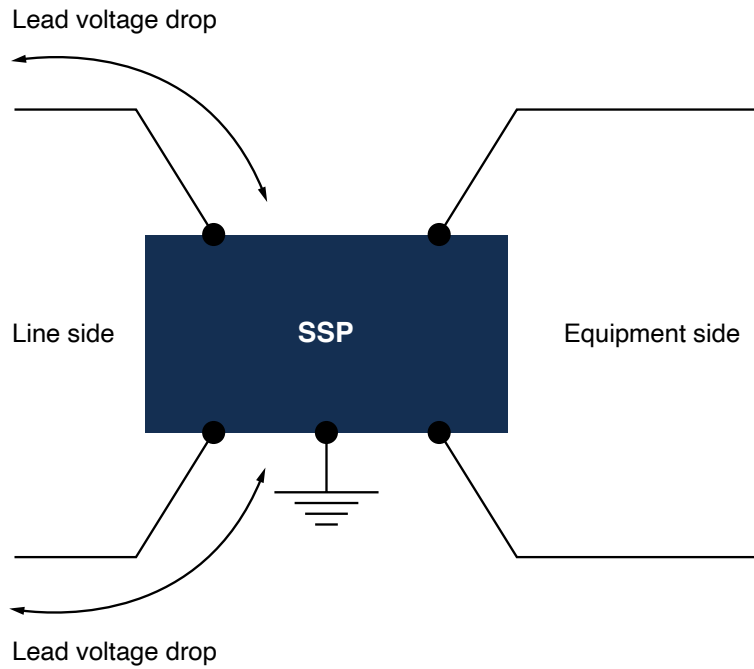

**Figure 3.** SSP Connections Showing How Lead Voltage Drop is Eliminated

The let through voltage of a typical SSP device is shown below.

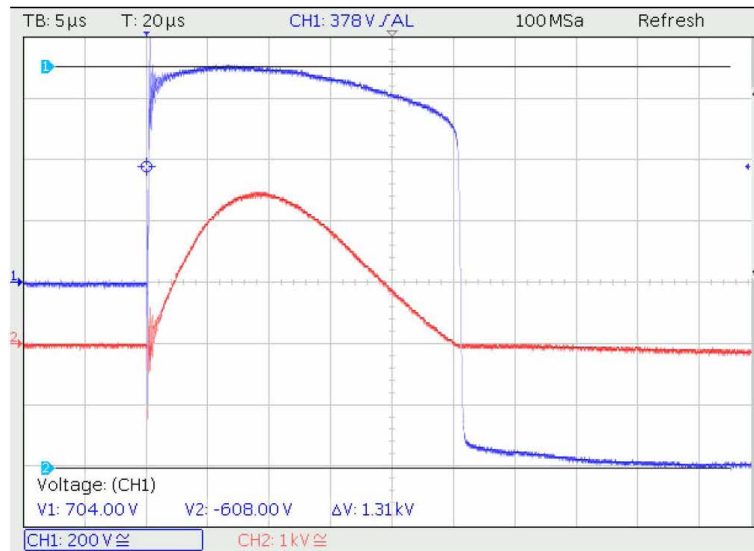

**Figure 4.** Let-through Voltage of a Typical SSP, 704 Volts

## Surge Filters

Surge filters are connected in series, they have two ports, Line side and Load side and must be connected in the correct orientation. They employ three-stage protection consisting of surge diverters at the input and output, and a low-pass LC filter in between. The low pass filter not only suppresses surges, but also provides some filtering against power harmonics and other high frequency conducted noise. In the event of a surge, the majority of the surge energy is diverted to ground by the stage 1 surge diverter. As a result, the voltage at the input to stage 2 is clamped.

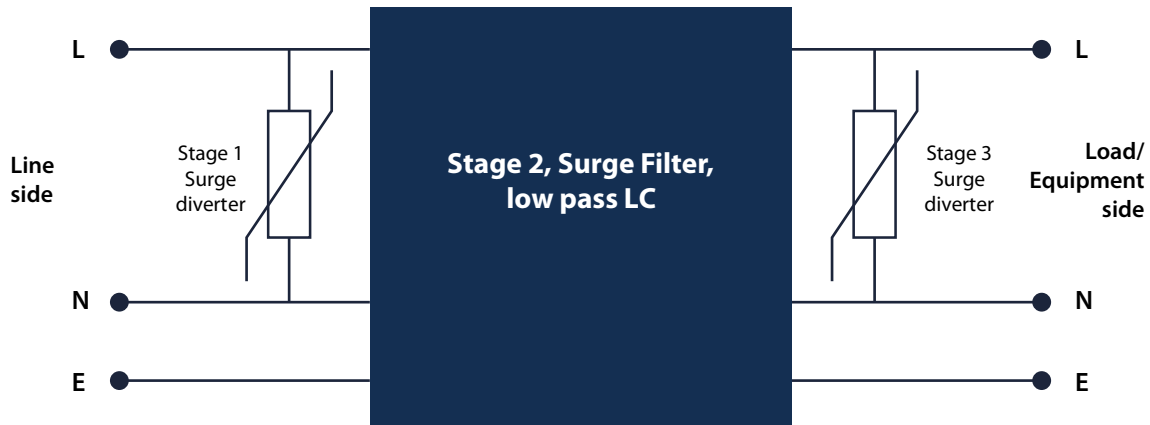

Figure 5. Surge Filter Configuration

The low-pass filter offers a low impedance to the power frequency applied, 50 or 60Hz, this allows 50-60Hz power to pass through with very low loss, whilst heavily attenuating the high frequency surge, power harmonics and other conducted noise. This leaves only a small surge for the stage 3 surge diverter to deal with. Typical values would be a 900V let-through voltage for stage 1 and a 600V drop across stage 2. This leaves only 300V ( $900 - 600 = 300$ ) at the output of the filter. Let-through voltages this low will protect even the most sensitive of electronic equipment.

A typical let-through voltage waveform for a surge filter is shown in Figure 6 below:

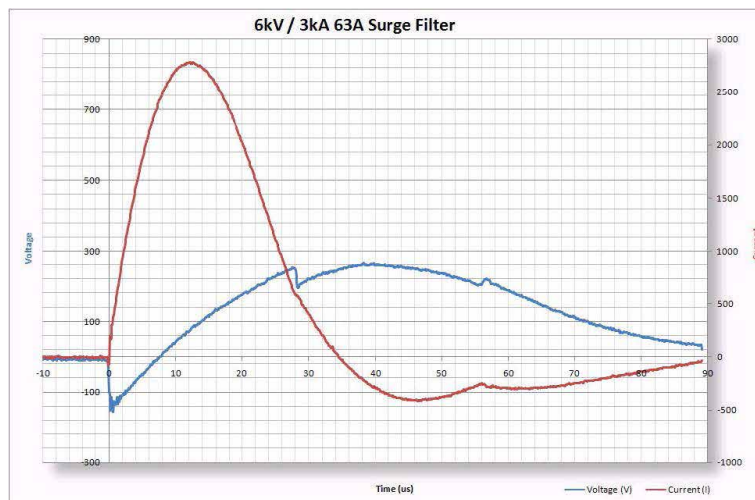
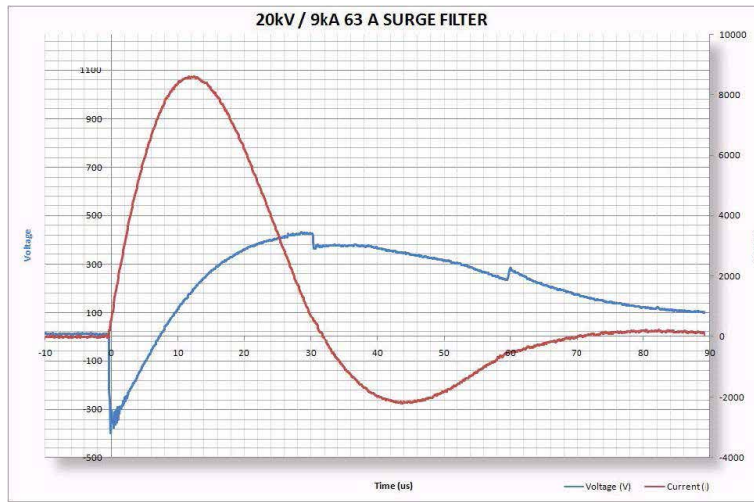

Figure 6. Typical Let-through Voltage of a Surge Filter (6kV / 3kA)

With the 20kV / 10kA waveform in Figure 7 we can again see the non-linear characteristics of the MOVs. With three times the current the let through voltage has only increased by 170V.



**Figure 7.** Typical Let-through Voltage of a Surge Filter (20kV / 10kA)

### Advantages of Surge Filters

Beside the fact that surge filters have a remarkably lower let-through voltage, they have other advantages over surge diverters.

#### **Effect of shunt-connected leads**

Because surge diverters are connected in parallel, the let-through voltage seen by the connected equipment depends not only upon the performance of the surge diverter, but also on the inductance of the connecting leads.

Figure 8 illustrates this principle:

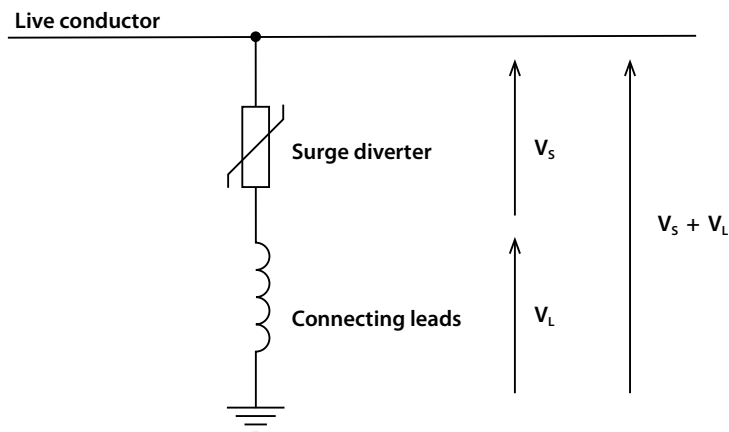

**Figure 8.** Effect of Shunt-connected Leads

Even if the inductance of the connecting leads is low, the extremely fast rise time of a lightning induced surge will create a very large voltage across them, represented by  $V_L$  in figure 6. Voltages can reach 200 volts / kA / m for a typical 6mm<sup>2</sup> cable used for switchboard connections.

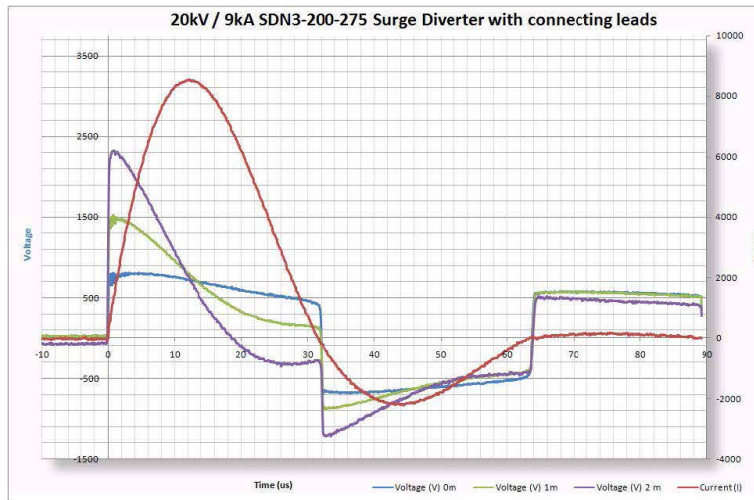

**Figure 9.** Let-through Voltage of a Surge Diverter With and Without Connecting Leads

Figure 9 shows that in a practical situation, the actual let-through voltage experienced by connected equipment can be much greater than that stated in the technical specifications for the surge diverter. The surge current causes a fast change in current which in turn increases the let through voltage due to wire inductance. This problem is not experienced with SSP's and surge filters because they are connected in series. The manufacturer establishes the length of all internal shunt-connected leads. This means:

- The SPD can be designed to minimise the lengths of connecting leads, therefore minimising the let-through voltage of the SSP or filter.
- The performance of the two port SPD is not installation dependant.
- The let-through voltage experienced by connected equipment in practical situations is always the same as that stated in the technical specifications for the SSP or filter.

### Lifespan and Reliability

Eventually, surge-diverting components are fatigued by repetitive and/or substantially sized surges. Because surge filters have three stages to a surge diverter's one, they tend to have a much longer lifespan, as well as increased reliability due to component redundancy. Novaris have performed extensive laboratory tests on surge filters that show the stage 1 surge diverter absorbs around 95% of the surge energy. This leaves only 5% of the surge energy for the stage 3 surge diverter to absorb. In all Novaris surge filters, the stage 3 surge diverter is generously rated. This provides a second line of defence should the stage 1 surge diverter fail. An additional advantage of the stage 3 surge diverter in a filter is that it protects against surges produced by connected equipment. This is particularly important when multiple loads are connected.

### Conclusions

The SSP and SF devices offer a much better level of protection to your equipment than a simple single port diverter. The best level of protection for your power line connected equipment is provided by Surge filters. Unlike surge diverters, their performance is not installation dependant. On top of these points, they offer filtering of power harmonics and other higher frequency noise, have a longer lifespan and are more reliable than surge diverters.

Novaris always recommends a Surge Filter be used where equipment is;

1. Sensitive electronics
2. Mission critical
3. High cost
4. High cost of downtime
5. Sensitive to harmonics and conducted power line noise

The table below shown the typical performance of the three types of power SPD so that engineers can specify the most appropriate type of SPD.

Type of Device	Typical Let Through Voltage
Diverter with 2 meters of connecting leads	2300V
Series Surge Protector (SSP)	700V
Surge Filter (SF)	450V

**Figure 10.** Comparison of SPD Performance

### Other Voltage and Protocol Protection

Novaris manufactures a full range of products for the protection of other voltages and protocols not mentioned in this application note.

For the complete range of Novaris products please see our Web site [www.novaris.com.au](http://www.novaris.com.au) or contact Novaris at [sales@novaris.com.au](mailto:sales@novaris.com.au)

