



NOVARIS

Application Note
(0015-D79V1)

SURGE PROTECTION FOR SOLAR PV SYSTEMS

Novaris Pty Ltd

72 Browns Road Kingston
P.O. Box 2010 Kingston
Tasmania 7050 Australia

+61 3 6229 7233
sales@novaris.com.au
www.novaris.com.au

CONTENTS

02

Introduction
Standards and Regulations
Background and Risks

03

Sources of Lightning Damage
Protection Options

04 - 05

Building without External LPS

06

Building with External LPS

07

Installations with Remote Self-supporting Panels
PV Panels with Built-in Inverters (Micro Inverters)

08

Battery Systems

09

Data Connections and Communications

10 - 12

Additional Notes on SPD's

Introduction

Like all electrical and electronic equipment solar photovoltaic systems can be damaged by electrical disturbances. These are most commonly caused by direct and indirect lightning effects, but also other overvoltage disturbances caused by electrical switching operations, load switching and other grid related transients.

Correct selection and application of Surge Protection Devices (SPD) can reduce or even eliminate damage to your PV system components and this application note provides guidance on all aspects of this process.

Standards and Regulations

Different countries use different standards to specify the use of SPDs and their application to different electrical systems including solar PV installations. The most often referenced standards used are the IEC standards. Specifically, these are IEC61643-31 for SPD performance and IEC61643-32 for the application of SPDs. For any potential installation the designer should check what local standards are applicable and ensure these are followed, this is especially important for the local regulations or rules for the AC side of the installation and how SPDs can be applied to the wiring system used in that country.

Background and Risks

Photovoltaic systems are designed to have an operational life of 25 years or more, so the chances of an electrical disturbance causing damage over this time is quite high. Protection against these disturbances will help to ensure that a long operational life and cost recovery is achieved.

Statistics on damage due to lightning induced overvoltages have shown that electronic installations up to about one kilometre from the strike point may be susceptible to induced or line-carried over voltages. In a region with a lightning ground flash density of just one flash per square kilometre per year this equates to potentially just over 60 disturbances over a 20 year period.

For comparison a typical domestic dwelling in the same region has about 1 chance in 100 of taking a direct lightning strike over that same 20 year period. Therefore, protection against indirect strikes assumes a greater importance.

Figure 1 shows the average world lightning flash density. Areas near the tropical regions have the highest incidence of lightning and therefore protection of solar PV installations in these regions is of greater importance if damage is to be avoided.

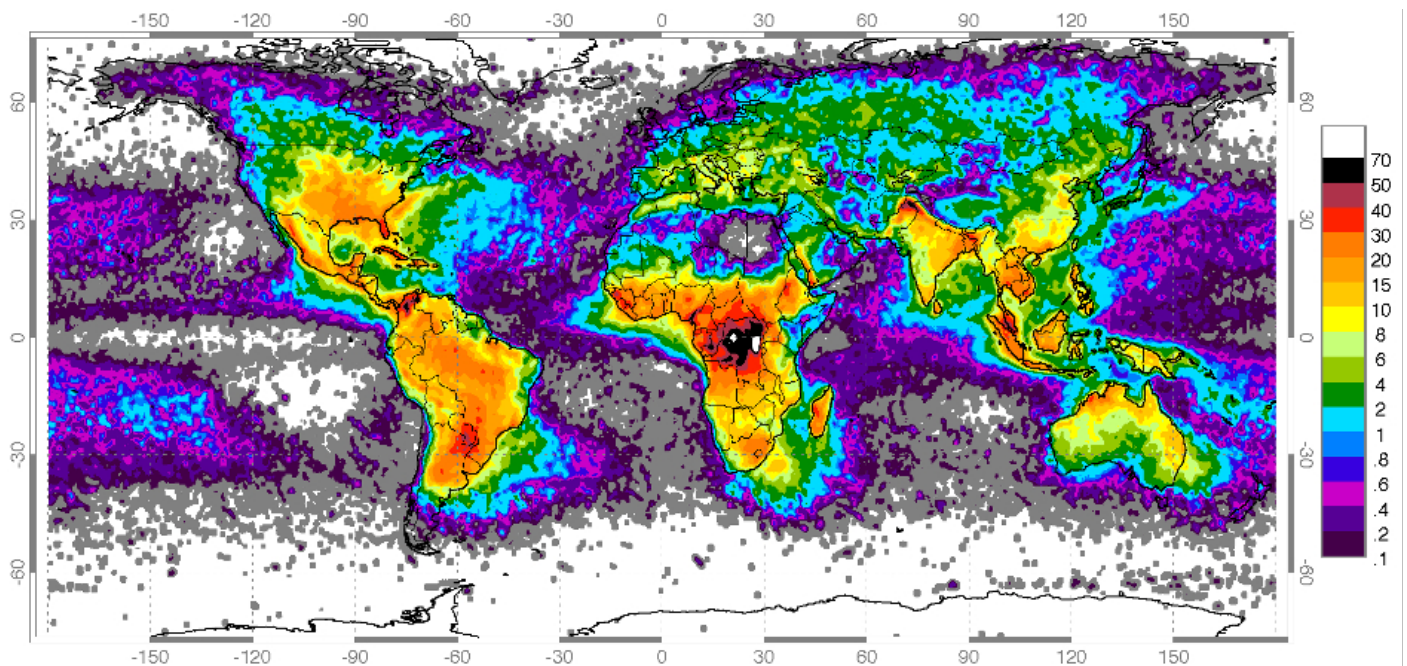

Figure 1. World Map of Lightning Flash Density

This application note applies specifically to grid connect solar PV systems but the general principles are equally applicable to remote area standalone PV systems. Remote area systems are obviously not prone to grid/line carried over voltages, but they can still be subjected to stand-by generator related load switching disturbances and the comments about induction due to remote lightning strikes equally apply.

Sources of Lightning Damage

Equipment may be damaged by either direct lightning strikes to the building or PV support structure, direct lightning strikes to the power line or from indirect strikes caused by cloud to ground or cloud to cloud strikes. These latter events cause magnetic and electric field induction as well as earth potential rises. It should be noted that transient electrical disturbances similar to lightning may be caused by power switching operations, including stand-by generators and power line faults.

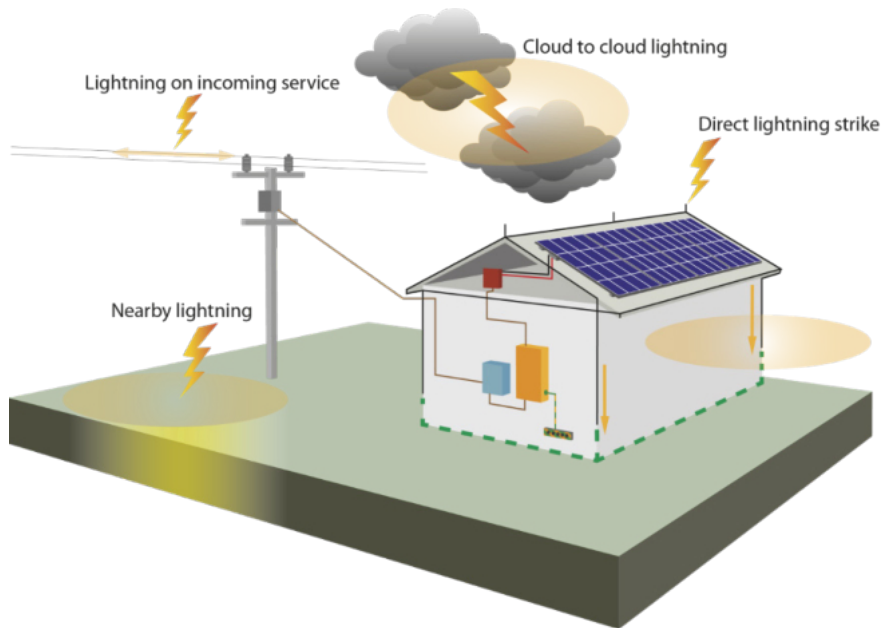

Figure 2. Sources of Lightning Damage

Protection Options

This application note follows the recommendations for lightning and surge protection set out in AS1768. There are two basic options to be considered before lightning and surge protection is applied. Depending upon whether the building has an external lightning protection system (LPS) will determine the selection and placement of SPD's.

In addition, this application note also has additional advice for these other scenarios.

1. When the panel array is mounted on a self-supporting frame and remote from the inverter(s)
2. The use of battery storage systems
3. The use of micro-inverters built into the panels
4. Connections used for monitoring and control

Note: An LPS is a system of connected electrically conducting elements installed onto a structure or building, most usually at the top and edges, that intercept any direct lightning downstrokes and pass these currents down to earth through a series of down conductors into an earthing system. By this means the large downstroke current does not damage the building structure itself, if non metallic or cause any fires in that structure.

Note: For installation and safety requirements for photovoltaic (PV) arrays please refer to AS5033.

Building without External LPS

This is by far the most common case where a building has no external LPS and so the risk of a direct lightning strike is not considered. This is the configuration that applies to 95% of residential solar PV installations in Australia. Figure 3 shows a building with roof mounted solar array and inverter mounted near the main switchboard. Normally the inverter would be mounted close to the main switchboard and in a location that is readily accessible, in accordance with AS/NZS5033.

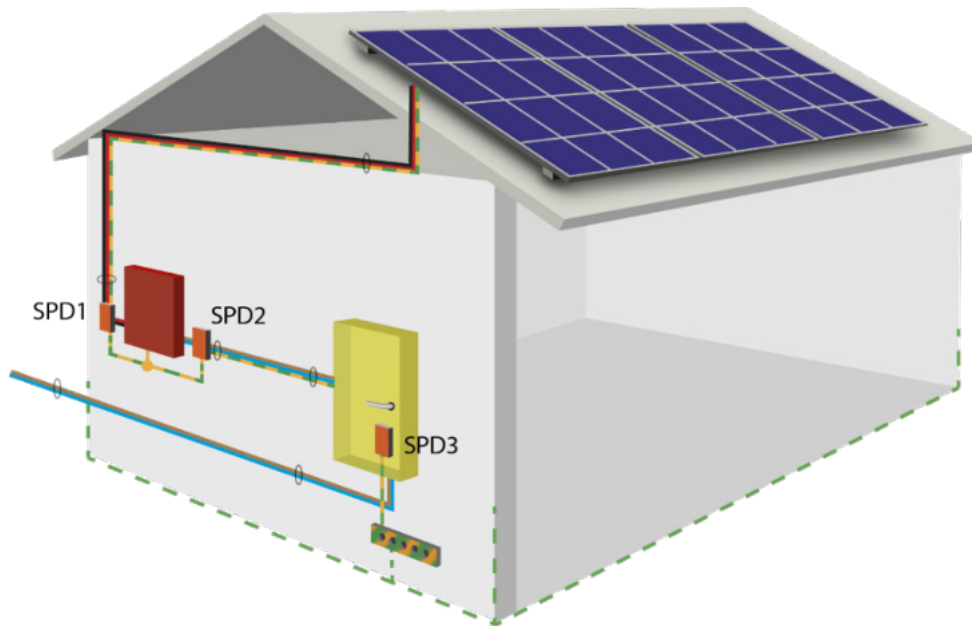

Figure 3. Building without LPS with Roof Mounted Panels

Protection in this case is required only against indirect lightning. Figure 4 below represents this as an electrical schematic.

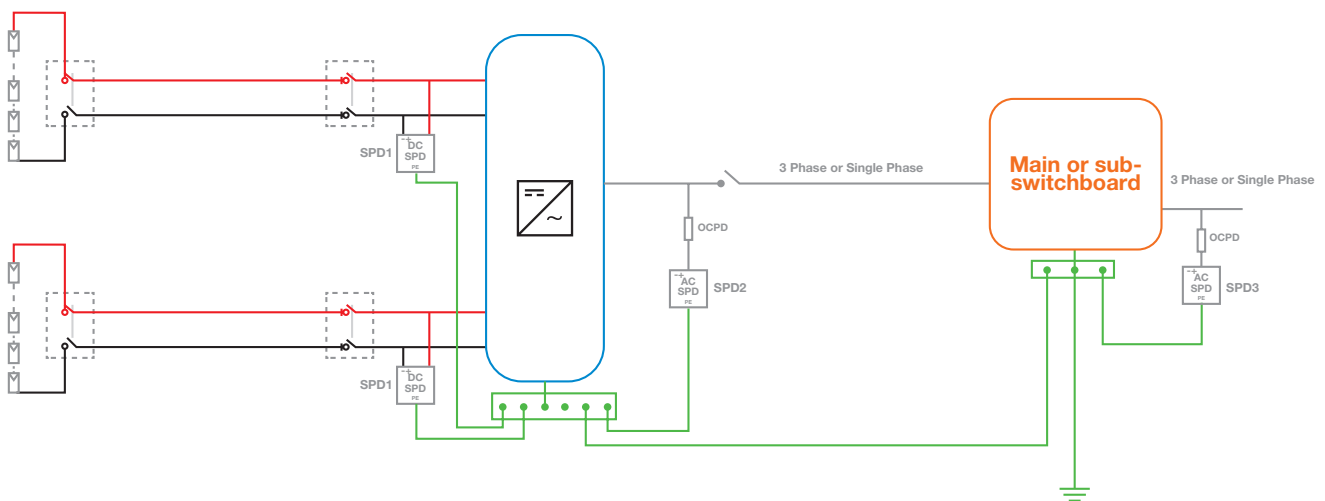

Figure 4. Electrical Schematic for Roof Mounted Panels with No Building LPS

The following is necessary to provide effective protection:

1. The DC cable to the inverter and 4mm² earth conductor must be run in the same conduit.
2. Install an SPD on the DC input to the inverter (SPD1 in figure 3). This SPD must be specifically designed for DC PV applications. AC SPDs are unsuitable and could present a hazard under fault conditions.
3. Install an SPD on the AC output of the inverter (SPD2 in figure 3). Whilst a shunt type surge diverter is suitable, more effective protection can be obtained by using a series connected shunt diverter, like the Novaris SSP, which eliminates the detrimental effects of lead inductance.
4. The protective earths of the SPDs and the frame earth of the inverter must be bonded together and in turn connected to the main earth bar as in figure 4. 4mm² cable is suitable.
5. Install an SPD on the incoming AC supply in the main switchboard (SPD3 in figure 3). A rating of $I_{max} = 50kA$ is suitable for most applications, 100kA should be used if the exposure is high.

If the length of cable from the inverter to the switchboard is less than 10 meters, SPD2 may be omitted and SPD3 provides primary protection for the switchboard and inverter.

The majority of installations can be successfully protected using this approach.

SPD Selection

The following tables list the Novaris products that are most suitable for the applications as referenced in Figure 4.

Number of Phases	Exposure Level	Novaris Part Number	SPD Type	Quantity Required
1	High	SDD1-100-275	Diverter	1
1	Medium	SDD1-50-275	Diverter	1
3	High	SDD3-100-275	Diverter	1
3	Medium	SDD3-50-275	Diverter	1

Table 1. SPD's for Main Switchboard Incoming Supply (SPD3)

Number of Phases	Surge Current Rating	Novaris Part Number	SPD Type	Quantity Required
1	<80kA	SCB1-3-80	Surge Circuit Breaker (SCB)	1
1	<80kA	SCB1-3-25	Surge Circuit Breaker (SCB)	1
3	<80kA	SCB1-3-80	Surge Circuit Breaker (SCB)	3
3	<80kA	SCB1-3-25	Surge Circuit Breaker (SCB)	3

Table 2. OCPD's for Protection of SPD's

Number of Phases	Surge Current Rating	Novaris Part Number	SPD Type	Quantity Required
1	High	SDD1-50-275	Diverter	1 per Inverter
1	Medium	SDD1-50-275	Diverter	1 per Inverter
3	High	SDD3-50-275	Diverter	1 per Inverter
3	Medium	SDD3-50-275	Diverter	1 per Inverter
1	Medium	SSP1-20-50-275	Series Surge Protector 20 Amps	1 per Inverter
1	Medium	SSP1-32-50-275	Series Surge Protector 32 Amps	1 per Inverter
1	Medium	SSP1-63-50-275	Series Surge Protector 63 Amps	1 per Inverter

Table 3. AC SPD's for Protection of Inverter Inputs (SPD2)

System Voltage	Exposure Level	Novaris Part Number	SPD Type	Quantity Required
600-1000 Volts DC	High	SDPV-100-1000	SD PV Diverter	1 per DC String
600-1000 Volts DC	Medium	SDPV-50-1000	SD PV Diverter	1 per DC String
600-1000 Volts DC	Domestic	SDPV-40-1000	SD PV Diverter	1 per DC String
1500 Volts DC	High and Medium	SDPV-50-1500	SD PV Diverter	1 per DC String

Table 4. DC SPDs for Protection of Inverter DC Inputs (SPD1)

Building with External LPS

Figure 5 and 6 shows a building with an external lightning protection system (LPS). In accordance with AS1768 the solar array frame must be bonded to the LPS. In this case the solar array frame and its earthing conductor form part of the LPS. Thus, partial lightning current will flow in the array bonding and earthing conductors. These must be sized accordingly and 35mm² cable is recommended in AS1768.

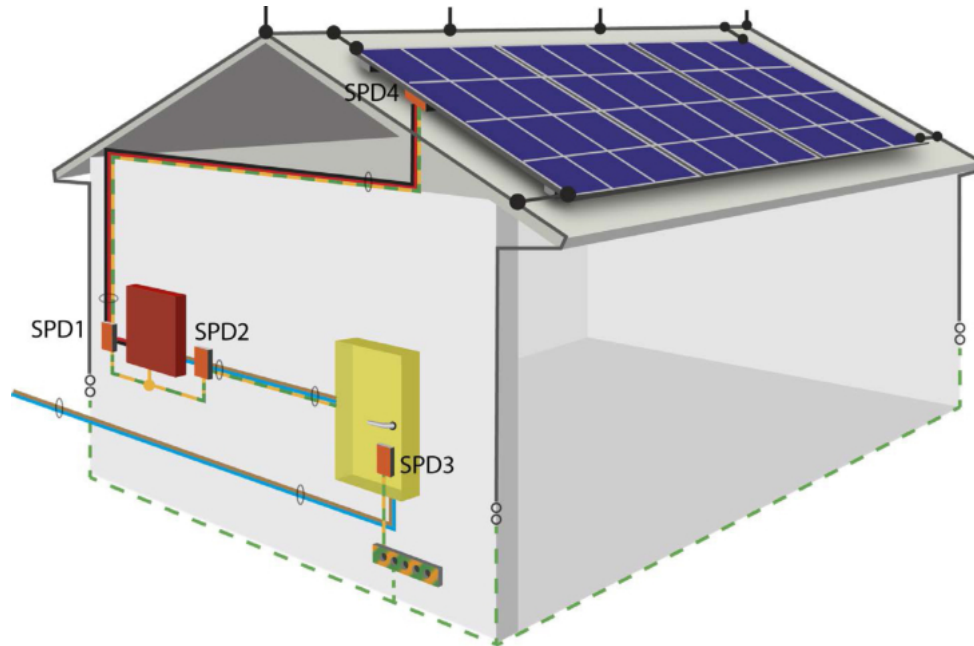

Figure 5. Building with LPS

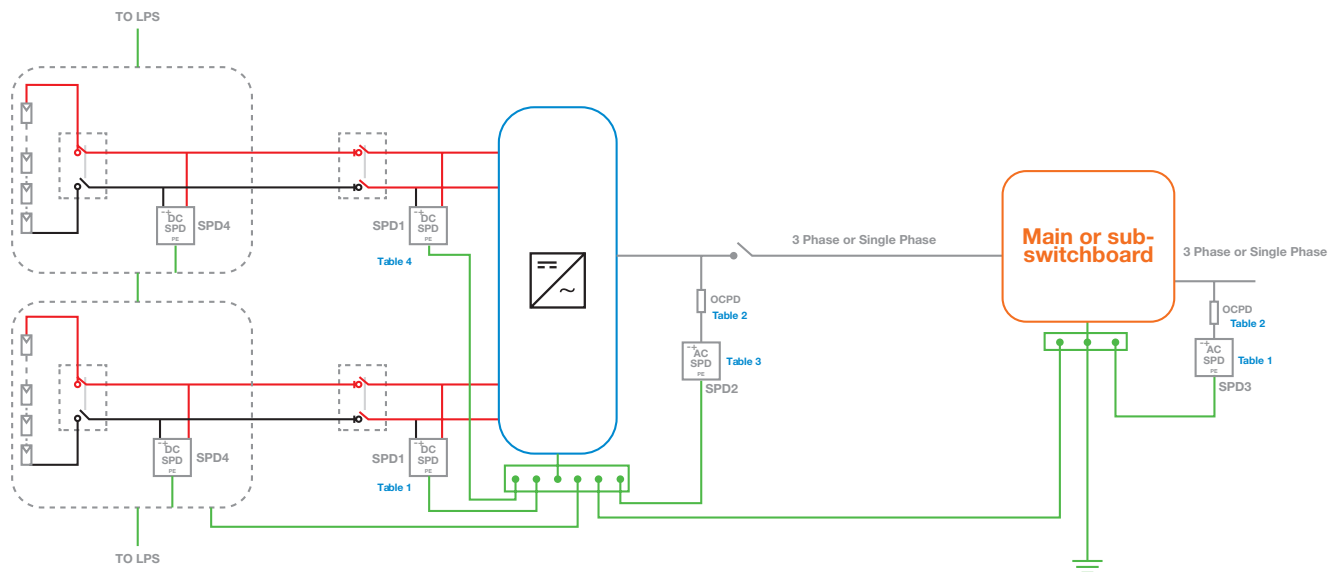

Figure 6. Electrical Schematic for Roof Mounted Panels with Building LPS

The following is recommended:

1. Bond the solar array frame to the LPS using 16mm² cable.
2. Install an SPD at the solar array (SPD4 in figure 5). This SPD must be specifically designed for DC PV applications. AC SPDs are unsuitable and could present a hazard under fault conditions. Connect the protective earth of the SPD to the solar array frame. Be aware that since this SPD is outdoors it must be housed in a suitable enclosure. AS/NZS5033 is quite specific on the type of enclosure required.
3. The DC cable to the inverter and earth conductor must be run in the same conduit.
4. Install an SPD on the DC input to the inverter (SPD1 in figure 5). This SPD must be specifically designed for DC PV applications. AC SPDs are unsuitable and could present a hazard under fault conditions.
5. Install an SPD on the AC output of the inverter (SPD2 in figure 5). Whilst a shunt type surge diverter is suitable more effective protection can be obtained by using a series connected shunt diverter, SSP type, which eliminates the detrimental effects of lead inductance.
6. The protective earths of the SPDs and the frame earth of the inverter shall be bonded together and in turn connected to the main earth bar via the main switchboard as in figure 6. 16mm² cable is suitable.
7. Install an SPD on the incoming AC supply in the main switchboard (SPD3 in figure 5).

If the length of cable from the inverter to the switchboard is less than 10 meters, SPD2 may be omitted and SPD3 provides primary protection for the switchboard and inverter.

SPD Selection

The following tables list the Novaris products that are most suitable for the applications as referenced in Figure 6.

Number of Phases	Exposure Level	Novaris Part Number	SPD Type	Quantity Required
1	High	SDD1-100-275	Diverter	1
1	Medium	SDD1-50-275	Diverter	1
3	High	SDD3-100-275	Diverter	1
3	Medium	SDD3-50-275	Diverter	1

Table 5. SPD's for Main Switchboard Incoming Supply (SPD3)

Number of Phases	Surge Current Rating	Novaris Part Number	SPD Type	Quantity Required
1	<80kA	SCB1-3-80	Surge Circuit Breaker (SCB)	1
1	<80kA	SCB1-3-25	Surge Circuit Breaker (SCB)	1
3	<80kA	SCB1-3-80	Surge Circuit Breaker (SCB)	3
3	<80kA	SCB1-3-25	Surge Circuit Breaker (SCB)	3

Table 6. OCPD's for Protection of SPD's

Number of Phases	Surge Current Rating	Novaris Part Number	SPD Type	Quantity Required
1	High	SDD1-50-275	Diverter	1 per Inverter
1	Medium	SDD1-50-275	Diverter	1 per Inverter
3	High	SDD3-50-275	Diverter	1 per Inverter
3	Medium	SDD3-50-275	Diverter	1 per Inverter
1	Medium	SSP1-20-50-275	Series Surge Protector 20 Amps	1 per Inverter
1	Medium	SSP1-32-50-275	Series Surge Protector 32 Amps	1 per Inverter
1	Medium	SSP1-63-50-275	Series Surge Protector 63 Amps	1 per Inverter

Table 7. AC SPD's for Protection of Inverter Inputs (SPD2)

System Voltage	Exposure Level	Novaris Part Number	SPD Type	Quantity Required
600-1000 Volts DC	High	SDPV-100-1000	SD PV Diverter	1 per DC String
600-1000 Volts DC	Medium	SDPV-50-1000	SD PV Diverter	1 per DC String
600-1000 Volts DC	Domestic	SDPV-40-1000	SD PV Diverter	1 per DC String
1500 Volts DC	High and Medium	SDPV-50-1500	SD PV Diverter	1 per DC String

Table 8. DC SPDs for Protection of Panels and Inverter DC Inputs (SPD1, SPD4)

Installations with remote self-supporting panels

Some solar PV systems particularly in remote or regional areas have the panels installed on a frame separate from the building or dwelling where the PV inverter is located. In this case the frame supporting the panels, and the panels themselves can be considered as an LPS. A risk assessment in accordance with AS1768 can be carried out to determine the need for lightning protection.

The panels should be bonded to the frame (assuming the frame is conductive, usually steel or aluminium) and the frame earthed via a system of local ground electrodes although the frame foundations will generally suffice for the lightning earth. Using the rolling sphere analysis in AS1768 the dimensions and spacing of air terminals attached to the frame can be determined.

The positioning and selection of SPD's for this configuration should follow that of a building with an LPS and this is detailed in section 2 of this application note. Refer to AS 1768 to determine the likely level of exposure of the site to lightning.

PV panels with built-in Inverters (Micro Inverters)

Each panel, or in some cases a small array of panels, are fitted with a small inverter usually mounted directly on the rear of the panel.

This means that there are only AC connections back to the premises switch board. Protection of these connections is can be achieved using suitably sized AC single phase surge diverters or series surge protectors.

Protection for these systems like the DC based systems can be broken into two scenarios.

a) **Where the building has an LPS or the panels are on a stand-alone support frame**

In this case SPD's are required to be installed at the panels close to the AC outputs or the AC junction box on the supporting frame. Connect the protective earth of these SPD's to the solar array frame. Be aware that since these SPD's are outdoors, they must be housed in a suitable weatherproof enclosure.

If the AC cables running back to the switchboard are longer than 10 meters then it is also recommended to install a suitable SPD in the switchboard on the main incoming AC grid connection.

b) **Where the building does not have an LPS**

In this case there is no need to have SPD's installed close to the panels on the roof or frame unless the cables to the switch board are longer than 10 meters. If the switchboard is over 10 meters from the closest inverter, then it is still recommended to install an SPD at each inverter location as well as in the switchboard on the main incoming AC grid connection.

Selection of AC SPD's for micro inverters is detailed in table 9 below.

Exposure Level	Length of Cable from Switchboard	Novaris Part Number	SPD Type	Quantity Required	Switchboard SPD Required
High	> 10 Meters	SDD1-100-275	Diverter	1 per AC Connection	Yes, as per Table 5
High	> 10 Meters	SDD1-100-275	Diverter	1 per AC Connection	No
Medium	> 10 Meters	SDD1-50-275	Diverter	1 per AC Connection	Yes, as per Table 5
Medium	> 10 Meters	SDD1-50-275	Diverter	1 per AC Connection	No
Medium and High	> 10 Meters	SSP1-20-50-275	Series Surge Protector 20 Amps	1 per AC Connection	Yes, as per Table 5
Medium and High	> 10 Meters	SSP1-20-50-275	Series Surge Protector 32 Amps	1 per AC Connection	No

Table 9. SPD's for Protection of Micro Inverters

Battery Systems

Battery storage systems are becoming more common on residential solar PV systems with the majority now consisting of self-contained Lithium-ion batteries of one technology or another combined with an inverter inside a housing.

These batteries are usually connected to the main switchboard where they can be charged from the PV output or the grid and then used to support the load during times when PV is not available and/or to supply certain circuits with power in the case of a loss of grid power. Most of the mainstream batteries have powerful control algorithms to allow the user to program the usage of the battery to match their circumstances, PV power, loads etc.

From the point of view of surge protection these batteries can be considered to be the same as the AC input side of a normal solar PV inverter and usually also have one or more data/control circuits.

Any SPD's installed at the battery location, for example where the cables from the battery to the switchboard are longer than 10 meters, the SPD should be earthed directly to the battery earth or chassis connection. A cable of 4mm² cable is suitable for this. The battery and switchboard earths should be bonded together with a 16mm² cable.

Selection of SPD's for the AC power connection to the battery should be made using Table 10 below for guidance:

Number of Phases	Length of Cable from Switchboard	Novaris Part Number	SPD Type	Quantity Required
1	>10 Meters	SDD1-100-275	Diverter	1 per Battery
1	5 - 10 Meters	SDD1-50-275	Diverter	1 per Battery
3	>10 Meters	SDD3-100-275	Diverter	1 per Battery
3	5 - 10 Meters	SDD3-50-275	Diverter	1 per Battery
1	5 - 10 Meters	SSP1-20-50-275	Series Surge Protector 20 Amps	1 per Battery
1	5 - 10 Meters	SSP1-32-50-275	Series Surge Protector 32 Amps	1 per Battery
1	5 - 10 Meters	SSP1-63-50-275	Series Surge Protector 63 Amps	1 per Battery

Table 10. SPD's for Battery AC Connections

Data Connections and Communications

Many of the current solar PV inverters and storage batteries have data connections that can be used to program them and retrieve operational data.

These connections are commonly a wired connection and as such are also exposed to the same disturbances at the power connections to the units. To protect the electronics of the inverter or battery these electrical ports also need to have suitable SPD's installed.

The following sections detail how to protect these data connections.

a) Ethernet

This is a high speed data connection usually connected using an RJ45 type connector. If the cable from the inverter or battery to the connection modem or hub is longer than 10 meters or they are earthed to separate earth systems then it is recommended to install an SPD at each end. The SPD should be grounded to the inverter or battery earth connection at that location and to the modem/hub earth connection at the other end. If the modem/hub doesn't have an earth connection then the SPD should be grounded to the closest available mains earth point. Table 11 below details the selection of Novaris Ethernet SPD's.

Type	Number of Ports	Novaris Part Number	Connection Type
Individual DIN Mounting	1	RJ45-1CAT6	RJ45
19 Inch Rack Mounting	8	RJ45-8CAT6	RJ45
19 Inch Rack Mounting	16	RJ45-16CAT6	RJ45
19 Inch Rack Mounting	24	RJ45-24CAT6	RJ45
DIN Mounting	8	DRJ45-8CAT6	RJ45
Weatherptooft	2	ORJ45-2CAT6	RJ45

Table 11. SPD's for Ethernet/LAN Connections

b) RS 485

RS485 is a serial connection protocol used for fixed wired data connections. If the cable from the inverter or battery to the control point is longer than 10 meters or they are earthed to separate earth systems then it is recommended to install an SPD at each end. The SPD should be grounded to the inverter or battery earth connection at that location and to cabinet or mains earth connection at the other end.

Novaris SPD's are available in two ranges to suit the level of exposure to surges and also with direct and indirect grounding options. If SPDs are installed at both ends of the circuit then one of the SPD's should have the indirect grounding option so as to avoid any earth loops and interference.

RS485 is normally based on 12 volt levels but some systems can use a higher voltage, this requires the use of a different SPD as detailed below. Table 12 below details the selection of Novaris RS485 SPD's.

Type	Exposure Level	Number of Pairs	Novaris Part Number	Exposure Level
DIN Rail SL	Medium	1	SL485	Direct Grounding
DIN Rail SL2	High	1	SL2-485	Direct Grounding
DIN Rail SL	Medium	1	SL485-EC90	Indirect Grounding
DIN Rail SL2	High	1	SL2-485-EC90	Indirect Grounding
DIN Rail SL	Medium	1	SL36	Up to 36 Volts Direct Grounding
DIN Rail SL2	High	1	SL2-36	Up to 36 Volts Direct Grounding
DIN Rail SL	Medium	1	SL36-EC90	Up to 36 Volts Indirect Grounding
DIN Rail SL2	High	1	SL2-36-EC90	Up to 36 Volts Indirect Grounding
DIN Rail SL4	High	1	SL4-485	Direct Grounding

Table 12. SPD's for RS485 data connections

c) Current and voltage sensors

If these sensors are installed inside the equipment, then it is likely that no additional surge protection will be required. If sensors are installed remote from the equipment, such as in a switchboard with cables longer than 2-3 M then surge protection may be required to avoid damage to the sensors and/or the equipment they are connected to.

These sensors are usually manufacturer specific and may require special SPD's to function correctly.

Consult to Novaris Product Handbook or the Novaris website <http://www.novaris.com.au/> for more guidance on selecting appropriate SPD products.

Additional notes on SPD's

a) SPD for DC PV

The SPD for the DC input to the inverter and solar array must be designed specifically for DC application. AC SPDs are not suitable because upon failure their disconnect circuitry may not quench the DC arc. AC SPDs rely upon a voltage zero crossing to quench the arc. This does not occur with DC. Thus, the arc may persist, with the attendant hazard of fire.

The standards relevant to the testing and performance of DC SPDs for PV application are EN50539-11 and IEC61643-31. All Novaris DC PV SPDs comply with these standards. The configuration is shown in figure 7, comprising all mode protection and equal let through voltage, U_p , from each line to earth and line to line.

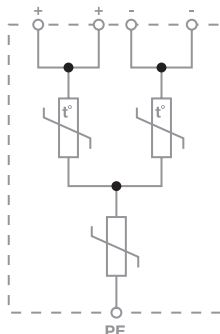

Figure 7. DC PV Configuration

The voltage clamping components are zinc oxide varistors. These are fitted with thermal disconnects and an arc quenching component.

Due to the characteristics of PV panels, over current fusing of DC PV SPDs is ineffective. The short circuit current from a typical PV string is limited and so an SPD fault even to a short circuit may not cause the fuse to trip. Figure 8 shows the typical characteristic of a solar panel. The short circuit current is very close to the maximum power point current. It is important to choose a DC PV SPD with a short circuit withstand current, I_{SCWSPV} , greater than the short circuit current of the solar array string, I_{SCPV} , to which the SPD is connected.

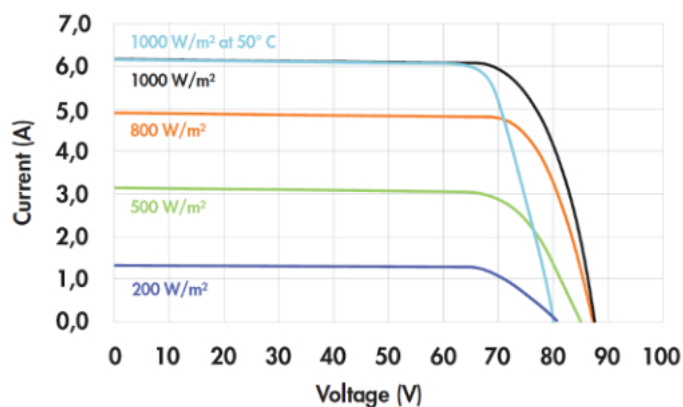

Figure 8. Typical Solar Panel Characteristic (Sunpower E19/425)

Table 13 below provides a specification summary for the Novaris DC PV SPD's.

Type	U_{CPV}	I_{max}	I_n	U_p
SDPV-100-1000	1000V	100kA	40kA	<3200V
SDPV-50-1000	1000V	50kA	20kA	<4200V
SDPV-40-1000	1000V	40kA	20kA	<4200V
SDPV-50-1500	1500V	50kA	20kA	<4000V

Table 13. Novaris SDPV Product Specifications

U_{CPV}	Maximum continuous operating voltage
I_{max}	Maximum discharge current (8/20us)
I_n	Nominal discharge current (8/20us)
U_p	Voltage protection level AS1768, IEC61643-21



Figure 9. Typical Novaris SDPV SPD

b) SPD for AC with special conditions

Novaris has a full range of AC SPD's some of which are specifically tailored to suit special conditions such a Temporary Over Voltage (ToV) conditions which can damage standard AC SPD's or trip out the OCPD. Other units such as surge filters provide better protection for sensitive electronics and others for extremely exposed locations where a higher level of I_{max} is required.

Table 14 below provides a summary of the available units for these special conditions. For further and more detailed information please contact Novaris.

	Quality of protection						
	←						
	Excellent	Excellent for TOV Solutions	Good for TOV Solutions	Good for Pole Mounted Supply	Good for Underground Supply	Good for Inverter AC Input if Supply Point MSB Also Has an SPD	Basic for Inverter AC Input
SPD Type	Surge Filter	Hybrid Surge Filter	Hybrid Spark Gap Diverter	Surge Diverter 200kA	Surge Diverter 100kA	Series Surge Protector 50kA	Surge Diverter 50kA
Three Phase Models	SFM3-*-100-275	HSF3-*-100-275	HSG3-100-480	SD3-200-275	SD3-100-275	SSP3-*-50-275	SDD3-50-275
Single Phase Models	SFM1-*-100-275	HSF1-*-100-275	HSG1-200-480	SD1-200-275	SD1-100-275	SSP1-*-50-275	SDD1-50-275
Notes	* rated maximum line current	* rated maximum line current				* rated maximum line current	

Table 14. Selection of AC SPD's for Special Conditions

c) AC SPD characteristics

SPDs for AC protection may be either SDD, surge diverters or SSP, series surge protectors. Table 15 below summarises the characteristics of the AC SPD's detailed in this application note.

Model	U _c	I _L	I _{max}	I _n	I _{SCCR}	U _p
SDD1-50-275	275V	N/A	50kA	20kA	25kA	<800V
SDD3-50-275	275V	N/A	50kA	20kA	25kA	<800V
SDD1-100-275	275V	N/A	100kA	40kA	50kA	<800V
SDD3-100-275	275V	N/A	100kA	40kA	50kA	<800V
SSP1-20-50-275	275V	20A	50kA	20kA	25kA	<800V
SSP1-32-50-275	275V	32A	50kA	20kA	25kA	<800V
SSP1-63-50-275	275V	63A	50kA	20kA	25kA	<800V

Table 15. Novaris AC SPDs

- U_c Maximum continuous operating voltage
- I_L Maximum load current
- I_{max} Maximum discharge current (8/20us)
- I_n Nominal discharge current (8/20us)
- I_{SCCR} Short-circuit current rating
- U_p Voltage protection level (in accordance with AS/NZS1768-2007)



Figure 10. Novaris AC SPDs SDD1-50-275 & SDD3-100-275